

UNITED STATES BANKRUPTCY COURT Middle District of Pennsylvania				VOLUNTARY PETITION	
Name of Debtor (if individual, enter Last, First, Middle): City of Harrisburg, PA			Name of Joint Debtor (Spouse) (Last, First, Middle): n/a		
All Other Names used by the Debtor in the last 8 years (include married, maiden, and trade names): n/a			All Other Names used by the Joint Debtor in the last 8 years (include married, maiden, and trade names):		
Last four digits of Soc. Sec. or Individual-Taxpayer I.D. (ITIN)/Complete EIN (if more than one, state all): 23-6002010			Last four digits of Soc. Sec. or Individual-Taxpayer I.D. (ITIN)/Complete EIN (if more than one, state all):		
Street Address of Debtor (No. and Street, City, and State): City Council For City of Harrisburg 101 North Second St, Suite 1, Lower level, Hbg, PA ZIP CODE 17101			Street Address of Joint Debtor (No. and Street, City, and State): ZIP CODE		
County of Residence or of the Principal Place of Business: Dauphin			County of Residence or of the Principal Place of Business:		
Mailing Address of Debtor (if different from street address): same as above ZIP CODE			Mailing Address of Joint Debtor (if different from street address): ZIP CODE		
Location of Principal Assets of Business Debtor (if different from street address above): ZIP CODE					
Type of Debtor (Form of Organization) (Check one box.) <input type="checkbox"/> Individual (includes Joint Debtors) <i>See Exhibit D on page 2 of this form.</i> <input type="checkbox"/> Corporation (includes LLC and LLP) <input type="checkbox"/> Partnership <input checked="" type="checkbox"/> Other (If debtor is not one of the above entities, check this box and state type of entity below.) Municipality _____	Nature of Business (Check one box.) <input type="checkbox"/> Health Care Business <input type="checkbox"/> Single Asset Real Estate as defined in 11 U.S.C. § 101(51B) <input type="checkbox"/> Railroad <input type="checkbox"/> Stockbroker <input type="checkbox"/> Commodity Broker <input type="checkbox"/> Clearing Bank <input checked="" type="checkbox"/> Other Municipality _____ Tax-Exempt Entity (Check box, if applicable.) <input checked="" type="checkbox"/> Debtor is a tax-exempt organization under Title 26 of the United States Code (the Internal Revenue Code).	Chapter of Bankruptcy Code Under Which the Petition is Filed (Check one box.) <input type="checkbox"/> Chapter 7 <input type="checkbox"/> Chapter 15 Petition for Recognition of a Foreign Main Proceeding <input checked="" type="checkbox"/> Chapter 9 <input type="checkbox"/> Chapter 15 Petition for Recognition of a Foreign Nonmain Proceeding <input type="checkbox"/> Chapter 11 <input type="checkbox"/> Chapter 12 <input type="checkbox"/> Chapter 13 Nature of Debts (Check one box.) <input type="checkbox"/> Debts are primarily consumer debts, defined in 11 U.S.C. § 101(8) as "incurred by an individual primarily for a personal, family, or household purpose." <input checked="" type="checkbox"/> Debts are primarily business debts.			
Filing Fee (Check one box.) <input checked="" type="checkbox"/> Full Filing Fee attached. <input type="checkbox"/> Filing Fee to be paid in installments (applicable to individuals only). Must attach signed application for the court's consideration certifying that the debtor is unable to pay fee except in installments. Rule 1006(b). See Official Form 3A. <input type="checkbox"/> Filing Fee waiver requested (applicable to chapter 7 individuals only). Must attach signed application for the court's consideration. See Official Form 3B.		Chapter 11 Debtors Check one box: <input type="checkbox"/> Debtor is a small business debtor as defined in 11 U.S.C. § 101(51D). <input type="checkbox"/> Debtor is not a small business debtor as defined in 11 U.S.C. § 101(51D). Check if: <input type="checkbox"/> Debtor's aggregate noncontingent liquidated debts (excluding debts owed to insiders or affiliates) are less than \$2,343,300 (amount subject to adjustment on 4/01/13 and every three years thereafter). Check all applicable boxes: <input type="checkbox"/> A plan is being filed with this petition. <input type="checkbox"/> Acceptances of the plan were solicited prepetition from one or more classes of creditors, in accordance with 11 U.S.C. § 1126(b).			
Statistical/Administrative Information <input checked="" type="checkbox"/> Debtor estimates that funds will be available for distribution to unsecured creditors. <input type="checkbox"/> Debtor estimates that, after any exempt property is excluded and administrative expenses paid, there will be no funds available for distribution to unsecured creditors.					THIS SPACE IS FOR COURT USE ONLY This document is deemed filed on October 11, 2011 pursuant to L.B.R. 5005-5-10:30 p.m. Filing Papers After Hours.
Estimated Number of Creditors <input checked="" type="checkbox"/> 1-49 <input type="checkbox"/> 50-99 <input type="checkbox"/> 100-199 <input type="checkbox"/> 200-999 <input type="checkbox"/> 1,000-5,000 <input type="checkbox"/> 5,001-10,000 <input type="checkbox"/> 10,001-25,000 <input type="checkbox"/> 25,001-50,000 <input type="checkbox"/> 50,001-100,000 <input type="checkbox"/> Over 100,000					
Estimated Assets <input type="checkbox"/> \$0 to \$50,000 <input type="checkbox"/> \$50,001 to \$100,000 <input type="checkbox"/> \$100,001 to \$500,000 <input type="checkbox"/> \$500,001 to \$1 million <input type="checkbox"/> \$1,000,001 to \$10 million <input type="checkbox"/> \$10,000,001 to \$50 million <input type="checkbox"/> \$50,000,001 to \$100 million <input checked="" type="checkbox"/> \$100,000,001 to \$500 million <input type="checkbox"/> \$500,000,001 to \$1 billion <input type="checkbox"/> More than \$1 billion					
Estimated Liabilities <input type="checkbox"/> \$0 to \$50,000 <input type="checkbox"/> \$50,001 to \$100,000 <input type="checkbox"/> \$100,001 to \$500,000 <input type="checkbox"/> \$500,001 to \$1 million <input type="checkbox"/> \$1,000,001 to \$10 million <input type="checkbox"/> \$10,000,001 to \$50 million <input type="checkbox"/> \$50,000,001 to \$100 million <input checked="" type="checkbox"/> \$100,000,001 to \$500 million <input type="checkbox"/> \$500,000,001 to \$1 billion <input type="checkbox"/> More than \$1 billion					

Voluntary Petition <i>(This page must be completed and filed in every case.)</i>		Name of Debtor(s): City of Harrisburg	
All Prior Bankruptcy Cases Filed Within Last 8 Years (If more than two, attach additional sheet.)			
Location Where Filed: none	Case Number:	Date Filed:	
Location Where Filed:	Case Number:	Date Filed:	
Pending Bankruptcy Case Filed by any Spouse, Partner, or Affiliate of this Debtor (If more than one, attach additional sheet.)			
Name of Debtor:	Case Number:	Date Filed:	
District: Middle District of Pennsylvania	Relationship:	Judge:	
<p style="text-align: center;">Exhibit A</p> <p>(To be completed if debtor is required to file periodic reports (e.g., forms 10K and 10Q) with the Securities and Exchange Commission pursuant to Section 13 or 15(d) of the Securities Exchange Act of 1934 and is requesting relief under chapter 11.)</p> <p><input type="checkbox"/> Exhibit A is attached and made a part of this petition.</p>	<p style="text-align: center;">Exhibit B</p> <p>(To be completed if debtor is an individual whose debts are primarily consumer debts.)</p> <p>I, the attorney for the petitioner named in the foregoing petition, declare that I have informed the petitioner that [he or she] may proceed under chapter 7, 11, 12, or 13 of title 11, United States Code, and have explained the relief available under each such chapter. I further certify that I have delivered to the debtor the notice required by 11 U.S.C. § 342(b).</p> <p><input checked="" type="checkbox"/> <u> n/a </u> Signature of Attorney for Debtor(s) (Date)</p>		
Exhibit C			
Does the debtor own or have possession of any property that poses or is alleged to pose a threat of imminent and identifiable harm to public health or safety?			
<input type="checkbox"/> Yes, and Exhibit C is attached and made a part of this petition.			
<input checked="" type="checkbox"/> No.			
Exhibit D			
(To be completed by every individual debtor. If a joint petition is filed, each spouse must complete and attach a separate Exhibit D.)			
<input type="checkbox"/> Exhibit D completed and signed by the debtor is attached and made a part of this petition.			
If this is a joint petition:			
<input type="checkbox"/> Exhibit D also completed and signed by the joint debtor is attached and made a part of this petition.			
Information Regarding the Debtor - Venue (Check any applicable box.)			
<input checked="" type="checkbox"/> Debtor has been domiciled or has had a residence, principal place of business, or principal assets in this District for 180 days immediately preceding the date of this petition or for a longer part of such 180 days than in any other District.			
<input type="checkbox"/> There is a bankruptcy case concerning debtor's affiliate, general partner, or partnership pending in this District.			
<input type="checkbox"/> Debtor is a debtor in a foreign proceeding and has its principal place of business or principal assets in the United States in this District, or has no principal place of business or assets in the United States but is a defendant in an action or proceeding [in a federal or state court] in this District, or the interests of the parties will be served in regard to the relief sought in this District.			
Certification by a Debtor Who Resides as a Tenant of Residential Property (Check all applicable boxes.)			
<input type="checkbox"/> Landlord has a judgment against the debtor for possession of debtor's residence. (If box checked, complete the following.)			
<u> n/a </u> (Name of landlord that obtained judgment)			
_____ (Address of landlord)			
<input type="checkbox"/> Debtor claims that under applicable nonbankruptcy law, there are circumstances under which the debtor would be permitted to cure the entire monetary default that gave rise to the judgment for possession, after the judgment for possession was entered, and			
<input type="checkbox"/> Debtor has included with this petition the deposit with the court of any rent that would become due during the 30-day period after the filing of the petition.			
<input type="checkbox"/> Debtor certifies that he/she has served the Landlord with this certification. (11 U.S.C. § 362(l)).			

Voluntary Petition

(This page must be completed and filed in every case.)

Name of Debtor(s):
City of Harrisburg

Signatures

Signature(s) of Debtor(s) (Individual/Joint)

I declare under penalty of perjury that the information provided in this petition is true and correct.

[If petitioner is an individual whose debts are primarily consumer debts and has chosen to file under chapter 7] I am aware that I may proceed under chapter 7, 11, 12 or 13 of title 11, United States Code, understand the relief available under each such chapter, and choose to proceed under chapter 7.

[If no attorney represents me and no bankruptcy petition preparer signs the petition] I have obtained and read the notice required by 11 U.S.C. § 342(b).

I request relief in accordance with the chapter of title 11, United States Code, specified in this petition.

X _____
Signature of Debtor

X _____
Signature of Joint Debtor

Telephone Number (if not represented by attorney)

Date

Signature of a Foreign Representative

I declare under penalty of perjury that the information provided in this petition is true and correct, that I am the foreign representative of a debtor in a foreign proceeding, and that I am authorized to file this petition.

(Check only one box.)

I request relief in accordance with chapter 15 of title 11, United States Code. Certified copies of the documents required by 11 U.S.C. § 1515 are attached.

Pursuant to 11 U.S.C. § 1511, I request relief in accordance with the chapter of title 11 specified in this petition. A certified copy of the order granting recognition of the foreign main proceeding is attached.

X _____
(Signature of Foreign Representative)

(Printed Name of Foreign Representative)

Date

Signature of Attorney*

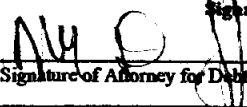
X  _____
Signature of Attorney for Debtor(s)

Printed Name of Attorney for Debtor(s)
Mark D. Schwartz, Bar No.

Firm Name

Address

Telephone Number

Date

*In a case in which § 707(b)(4)(D) applies, this signature also constitutes a certification that the attorney has no knowledge after an inquiry that the information in the schedules is incorrect.

Signature of Non-Attorney Bankruptcy Petition Preparer

I declare under penalty of perjury that: (1) I am a bankruptcy petition preparer as defined in 11 U.S.C. § 110; (2) I prepared this document for compensation and have provided the debtor with a copy of this document and the notices and information required under 11 U.S.C. §§ 110(b), 110(h), and 342(b); and, (3) if rules or guidelines have been promulgated pursuant to 11 U.S.C. § 110(h) setting a maximum fee for services chargeable by bankruptcy petition preparers, I have given the debtor notice of the maximum amount before preparing any document for filing for a debtor or accepting any fee from the debtor, as required in that section. Official Form 19 is attached.

Printed Name and title, if any, of Bankruptcy Petition Preparer

Social-Security number (If the bankruptcy petition preparer is not an individual, state the Social-Security number of the officer, principal, responsible person or partner of the bankruptcy petition preparer.) (Required by 11 U.S.C. § 110.)

X _____
Address

Date

Signature of bankruptcy petition preparer or officer, principal, responsible person, or partner whose Social-Security number is provided above.

Names and Social-Security numbers of all other individuals who prepared or assisted in preparing this document unless the bankruptcy petition preparer is not an individual.

If more than one person prepared this document, attach additional sheets conforming to the appropriate official form for each person.

A bankruptcy petition preparer's failure to comply with the provisions of title 11 and the Federal Rules of Bankruptcy Procedure may result in fines or imprisonment or both. 11 U.S.C. § 110; 18 U.S.C. § 156.

Signature of Debtor (Corporation/Partnership)

I declare under penalty of perjury that the information provided in this petition is true and correct, and that I have been authorized to file this petition on behalf of the debtor.

The debtor requests the relief in accordance with the chapter of title 11, United States Code, specified in this petition:

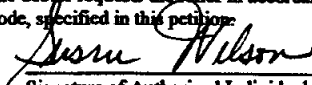
X  _____
Signature of Authorized Individual

SUSAN WILSON
Printed Name of Authorized Individual

CITY COUNCIL MEMBER - BUDGET & FINANCE CHAIR
Title of Authorized Individual

10/11/2011
Date

[If, to the best of the debtor's knowledge, the debtor owns or has possession of property that poses or is alleged to pose a threat of imminent and identifiable harm to the public health or safety, attach this Exhibit "C" to the petition.]

UNITED STATES BANKRUPTCY COURT

Middle District of Pennsylvania

In re	<u>City of Harrisburg</u>	,)	Case No.	<u>11-</u>
	Debtor)		
)		
)	Chapter	<u>9</u>

EXHIBIT "C" TO VOLUNTARY PETITION

1. Identify and briefly describe all real or personal property owned by or in possession of the debtor that, to the best of the debtor's knowledge, poses or is alleged to pose a threat of imminent and identifiable harm to the public health or safety (attach additional sheets if necessary):

None

2. With respect to each parcel of real property or item of personal property identified in question 1, describe the nature and location of the dangerous condition, whether environmental or otherwise, that poses or is alleged to pose a threat of imminent and identifiable harm to the public health or safety (attach additional sheets if necessary):

The Debtor is not aware of any definition of "imminent and identifiable harm" as used in this form. The Debtor does not believe that it owns or possesses property that poses or is alleged to pose a threat of such harm.

IN THE UNITED STATES BANKRUPTCY COURT
FOR THE MIDDLE DISTRICT OF PENNSYLVANIA

In Re: : Chapter 9
: :
: :
CITY OF HARRISBURG : Case No.

LIST OF CREDITORS AND CLAIMS PURSUANT TO 11 U.S.C. §§ 924 AND 925

Pursuant to 11 U.S.C. § 924 and Rule 1007(a) and (e) of the Federal Rules of Bankruptcy Procedures, the City of Harrisburg, Dauphin County, Pennsylvania (the "City"), by and through its undersigned counsel, hereby submits its List of Creditors and Claims Pursuant to 11 U.S.C. §§ 924 and 925 (the "Creditors List"). The Creditors List constitutes the list of claims under 11 U.S.C. § 925.

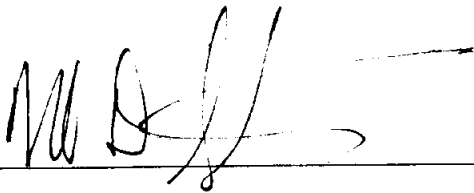

Mark D. Schwartz
David A. Gradwohl

Counsel for Debtor
City of Harrisburg

IN THE UNITED STATES BANKRUPTCY COURT
FOR THE MIDDLE DISTRICT OF PENNSYLVANIA

In Re: : Chapter 9
: :
: :
CITY OF HARRISBURG : Case No.

**DECLARATION UNDER PENALTY OF PERJURY ON BEHALF OF A
MUNICIPALITY**

I, ^{Susan Wilson} [~~name of repre. of City~~], am the authorized officer or agent of the municipality named as the Debtor in this case. I declare under penalty of perjury that I have read the foregoing List of Creditors and Claims Pursuant to 11 U.S.C. §§ 924 and 925 and that it is true and correct to the best of my information and belief.

*Susan Wilson, Budget & Finance
Chair.*

Dated: October 11, 2011

Title:
City of Harrisburg

Penalty for making a false statement or concealing property: Fine of up to \$500,000 or imprisonment for up to 5 years or both. 18 U.S.C. §§ 152 and 3571.

List of Creditors And Claims

CREDITOR	ADDRESS 1	ADDRESS 2	CITY	STATE	ZIP CODE	CREDITOR CONTACT	AMOUNT OF CLAIM	NATURE OF CLAIM
Ambac (Insurer)	One State Street Plaza		New York	NY	10004		\$31,642,634	General Obligation Bonds Ser D of 1997. Repaid from General Fund Revenues. Matures 9/15/22. <small>As of 1/1/2012</small>
Ambac (Insurer)	One State Street Plaza		New York	NY	10004		\$39,175,372	General Obligation Notes Ser F of 1997. Repaid from General Fund Revenues. Matures 9/15/22. <small>As of 1/1/2012</small>
Commonwealth of PA - PennDOT - Pennsylvania Infrastructure Bank	PO Box 3365		Harrisburg	PA	17105	Hugh J McGowan, PIB Manager	\$28,870	General Obligation Note Ser A of 2003. Repaid from General Fund Revenues. Matures 9/1/13. <small>As of 1/1/2012</small>
Commonwealth of PA - PennDOT - Pennsylvania Infrastructure Bank	PO Box 3365		Harrisburg	PA	17105	Hugh J McGowan, PIB Manager	\$78,257	General Obligation Note Ser B of 2003. Repaid from General Fund Revenues. Matures 9/1/13. <small>As of 1/1/2012</small>
Commonwealth of PA - PennDOT - Pennsylvania Infrastructure Bank	PO Box 3365		Harrisburg	PA	17105	Hugh J McGowan, PIB Manager	\$28,756	General Obligation Note Ser C of 2003. Repaid from General Fund Revenues. Matures 9/1/13. <small>As of 1/1/2012</small>
Commerce Bank	3801 Paxton St		Harrisburg	PA	17111	Commercial Business Department	\$3,216,146	Issued by the Harrisburg Redevelopment Authority. Proceeds and debt service to/by City of Harrisburg. <small>Estimated outstanding principal as of 1/1/2012</small>
Commonwealth of PA - PennDOT - Pennsylvania Infrastructure Bank	PO Box 3365		Harrisburg	PA	17105	Hugh J McGowan, PIB Manager	\$1,778,840	General Obligation Note. Repaid from General Fund Revenues. Matures 3/15/18. <small>As of 1/1/2012</small>

CREDITOR	ADDRESS 1	ADDRESS 2	CITY	STATE	ZIP CODE	CREDITOR CONTACT	AMOUNT OF CLAIM	NATURE OF CLAIM
Suntrust Bank	PO Box 79194		Baltimore	MD	21279		\$3,380,871	Capital Lease As of 1/1/2012
Bank of New York as Trustee	Corporate Trust & Billing Dept. PO Box 19445A		Newark	NJ	07195		\$11,205,000	The Harrisburg Authority, Guaranteed RRF Refunding Revenue Bonds Series A of 1998. Matures 9/1/2020. Estimated outstanding principal as of 1/1/2010
M&T Bank as Trustee							\$14,870,000	Guaranteed Federally Taxable RRF Subordinate Variable Rate Revenue Notes Series A of 2002. Matures 11/1/2022. Estimated outstanding principal as of 1/1/2010
TD Bank as Trustee							\$22,555,000	Guaranteed RRF Subordinate Revenue and Refunding Revenue Bonds Series A of 2003. Matures 9/1/2034. Estimated outstanding principal as of 1/1/2010
TD Bank as Trustee							\$29,085,000	Guaranteed Federally Taxable RRF Subordinate Variable Rate Refunding Revenue Notes Series B of 2003. Matures 9/1/2034. Estimated outstanding principal as of 1/1/2010
TD Bank as Trustee							\$24,285,000	Guaranteed RRF Subordinate Refunding Revenue Notes Series C of 2003. Matures 9/1/2034. Estimated outstanding principal as of 1/1/2010
TD Bank as Trustee							\$96,480,000	Guaranteed RRF Revenue Bonds Series D-1 and D-2 of 2003. Matures 12/1/2033. Estimated outstanding principal as of 1/1/2010

CREDITOR	ADDRESS 1	ADDRESS 2	CITY	STATE	ZIP CODE	CREDITOR CONTACT	AMOUNT OF CLAIM	NATURE OF CLAIM
TD Bank as Trustee							\$13,110,000	Guaranteed Federally Taxable RRF Revenue Bonds Series E of 2003. Matures 12/1/2011 and 12/1/2017. Estimated outstanding principal as of 1/1/2010
TD Bank as Trustee							\$12,680,000	Guaranteed Federally Taxable RRF Revenue Bonds Series F of 2003. Matures 12/1/2011 and 12/1/2017. Estimated outstanding principal as of 1/1/2010
TD Bank as Trustee							\$20,951,574	Guaranteed RRF Limited Obligation Notes Series C of 2007. Matures 12/15/2010. Refinanced by Dauphin County. No documents available.
TD Bank as Trustee							\$9,033,234	Guaranteed RRF Limited Obligation Notes Series D of 2007. Matures 12/15/2010. Refinanced by Dauphin County. No documents available.
Covanta	Covanta Holding Corp. 445 S St		Morristown	NJ	07960		\$23,587,500	Advance from Covanta to THA guaranteed by City. Matures 7/1/2018. Estimated outstanding principal as of 1/1/2010
							\$11,800,000	Guaranteed Parking Revenue bonds Series K of 2000. As of 1/1/2012
							\$26,940,000	Guaranteed Parking Revenue bonds Series J of 2001. As of 1/1/2012
							\$3,470,000	Guaranteed Parking Revenue bonds Series N of 2003. As of 1/1/2012
							\$7,865,000	Guaranteed Parking Revenue bonds Series O of 2003. As of 1/1/2012
							\$16,510,000	Guaranteed Parking Revenue bonds Series P of 2005. As of 1/1/2012

CREDITOR	ADDRESS 1	ADDRESS 2	CITY	STATE	ZIP CODE	CREDITOR CONTACT	AMOUNT OF CLAIM	NATURE OF CLAIM
							\$16,270,000	Guaranteed Parking Revenue bonds Series R of 2007. <small>As of 1/1/2012</small>
							\$17,980,000	Guaranteed Parking Revenue bonds Series T of 2007. <small>As of 1/1/2012</small>

IN THE UNITED STATES BANKRUPTCY COURT
FOR THE MIDDLE DISTRICT OF PENNSYLVANIA

In Re: : Chapter 9
: :
: :
CITY OF HARRISBURG : Case No.

STATEMENT OF QUALIFICATIONS UNDER SECTION 109(c)

The City of Harrisburg, Dauphin County, Pennsylvania (the “City”), by and through its undersigned counsel, hereby certifies that it is qualified to be a debtor under Chapter 9 of the Bankruptcy Code (the “Code”), 11 U.S.C. §§ 901—946, because it satisfies each of the following statutory criteria for eligibility as stated in pertinent part in 11 U.S.C. § 109(c):

- (c) An entity may be a debtor under chapter 9 of this title...if and only if such entity—
- (1) is a municipality;
 - (2) is specifically authorized, in its capacity as a municipality or by name, to be a debtor under such chapter ... by State law...;
 - (3) is insolvent;
 - (4) desires to effect a plan to adjust such debts; and

(5) ... (B) has negotiated in good faith with creditors and has obtained the agreement of creditors holding at least a majority in amount of the claims of each class that such entity intends to impair under a plan in a case under such chapter...; or

(C) has not negotiated with its creditors because such negotiations would not be practical; or

(D) reasonably believes that a creditor may attempt to obtain a transfer that is avoidable under section 547 of this title...

A. First Requirement: The City of Harrisburg is a Municipality.

The Code defines the term “municipality” as a “political subdivision or public agency or instrumentality of a State.” 11 U.S.C. §101(40). The City is a third class city of the Commonwealth of Pennsylvania, existing under provisions of the Third Class City Code, 53 P.S. § 35101, et seq., and operating pursuant to the Optional Third Class City Charter Law, 53 P.S. § 41101, et seq., with a business address at The Rev. Dr. Martin Luther King, Jr. City Government Center, 10 North Second Street, Harrisburg, Pa 17101. Thus, the City is a “municipality” within the meaning of the Code.

B. Second Requirement: The City Is Authorized By State Law To Be A Debtor.

Under state law a city of the third class, like the City of Harrisburg, is authorized to incur debts. See 53 P.S. § 35101 and § 41101. As a result, the City is a debtor as that term is generally

used in the Code. Moreover, under state law the City is authorized to be a debtor under Chapter 9.

In 1987, Pennsylvania enacted the Financially Distressed Municipalities Act, commonly known as “Act 47”, 53 P.S. §§11701.101, et seq. Section 261 of Act 47 authorizes a municipality “to file a municipal debt adjustment action pursuant to the Bankruptcy Code,” if any of several specified conditions is met, including:

(2) Imminent jeopardy of an action by a creditor, claimant or supplier of goods or services which is likely to substantially interrupt or restrict the continued ability of the municipality to provide health or safety services to its citizens.

(4) A condition substantially affecting the municipality’s financial distress is potentially solvable only by utilizing a remedy exclusively available to the municipality through the Federal Municipal Debt Readjustment Act (48 Stat. 798). [which was the predecessor to Chapter 9 of the Code].

(5) A majority of the current... governing body of a municipality determined to be financially distressed has failed to adopt a plan or to carry out the recommendation of the Coordinator pursuant to Act 47.

53 P.S. §11701.261.

The aforesaid conditions are met by the circumstances presented to the City Council, the City’s governing body under the Act, at this time. First, the City is in imminent jeopardy through six pending legal actions by creditors with respect to a number of outstanding bond issues relating to the Harrisburg Materials, Energy, Recycling and Recovery Facilities (the

“incinerator”) which processes waste into steam and electrical energy. The owner and operator of the incinerator is The Harrisburg Authority which is unable to pay the bond issues. The City is the primary Guarantor under each bond issue. The remedies demanded in those six legal actions would substantially interrupt the City’s ability to provide health or safety services to its citizens. Those cases are: (1) County of Dauphin v. The Harrisburg Authority and City of Harrisburg, No. 2011-CV-1618 (Dauphin Co. Court of Common Pleas Feb. 15, 2011); (2) The County of Dauphin and Joseph and Jacalyn Lahr v. City of Harrisburg, et al., No. 2009-CV-9271 (Dauphin Co. Court of Common Pleas July 22, 2009); (3) The County of Dauphin and Joseph and Jacalyn v. City of Harrisburg, et al., No. 1668-CV-2010 (Dauphin Co. Court of Common Pleas); (4) TD Bank, N.A. v. City of Harrisburg, et al., No 2010-CV-11738 (Dauphin Co. Court of Common Please October 5, 2010); (5) TD Bank, N.A., et al. v. City of Harrisburg, et al., No. 2010-CV-11737 (Dauphin Co. Court of Common Pleas Sept. 13, 2010); and (6) Covanta Harrisburg, Inc. v. City of Harrisburg, et al., No. 2010-CV-13120 (Dauphin Co. Court of Common Pleas October 5, 2010). Each case seeks a money judgment and a mandamus under § 8261 of the Debt Act which would require the City Treasurer to apply all tax moneys first to the repayment of the bonds. The City does not have the ability to pay those money judgments or any significant portion thereof and still provide health and safety services to its citizens and other essential government services. Further, the requested mandamus remedy would stop the City’s receipt of tax revenues to pay essential governmental operating services (e.g., fire, police, regulatory, etc.). Thus, the City is imminent jeopardy of creditor action within the meaning of Section 261(2) of Act 47.

Moreover, the creditors' actions seek money judgments of such a magnitude that is vastly beyond the ability of the City to pay, now or ever under current circumstances. The total principal amount guaranteed by the City is approximately \$242 million. The total past due amount subject to the guaranty is \$65 million. The City's financial problems can only be solved by utilizing the cram-down remedies available under the Code to scale down such debt, within the meaning of Section 261(4) of Act 47. Further, City Council has refused to accept the recommendations in a proposed Act 47 plan.

Since as the previous discussion demonstrates, the alternatives enumerated under Section 261 are met, and the City is specifically authorized by Pennsylvania law to file a Chapter 9 proceeding pursuant to the Code. Further, a majority of the City Council voted to authorize the commencement and prosecution of this case. See Act 47, Section 261(b). A true and correct copy of such Resolution is attached hereto as Exhibit "A" and incorporated herein by reference.

D. Third Requirement: The City Is Insolvent.

With respect to a municipality, the Code defines "insolvent" to mean a financial condition such that the municipality is "generally not paying its debts as they become due." 11 U.S.C. §101(32)(C)(i). While the term "generally not paying" is not defined by the Code, courts have adopted a "totality of the circumstances" test for determining whether a debtor is generally not paying its debts as that term is used in the requirements for a creditor to file an involuntary petition against a non-municipal debtor. See 11 U.S.C. §303(h)(1). As the bankruptcy treatise, Collier on Bankruptcy, notes, the question is how many debts are being paid in proportion to the

total number of debts. Not paying one significant creditor can satisfy the standard. 6 Collier on Bankruptcy § 303.31[1] and [2] (Resnick & Sommer eds. 2010). See *In re Amanat*, 321 B.R. 30, 39-40 (Bankr. S.D.N.Y. 2005) (where a debtor fails to pay even one debt that makes up a substantial portion of its overall liability, a court may find that the debtor is not paying its debts).

The City meets the “generally not paying” definition of insolvency, because it has repeatedly failed to pay the guaranteed incinerator bond debt as it has become due. The failure to pay that debt has generated the previously identified which seeks money judgments and a mandamus remedy that would prevent the City from providing essential services to its citizens. The magnitude of that debt is sufficiently large that it dwarfs the City’s other liabilities. Under the guaranties the City would need to cover a combined \$83 million of past due payments and the 2011 debt service. A true and correct copy of a chart showing the past due amounts owed under each bond issue is attached hereto as Exhibit B and C and are incorporated herein by reference. The City is financially strapped. It suffered a budget deficit of \$5.35 million in 2010, and it is projected to have a \$3.0 million deficit without paying any guaranteed bond obligations. A true and correct copy of a chart showing the City’s budget summary for 2010 and 2011 is attached hereto as Exhibit D and incorporated herein by reference. As a result, the City has not put any bond debt service payments in its 2011 budget. Accordingly, the City is generally not paying its debts and is insolvent.

D. Fourth Requirement: The City Desires To Effect A Plan To Adjust Its Debts.

The City's primary goal in filing this Chapter 9 Petition is to provide for some treatment of the outstanding guaranteed bond debt and to resolve the litigation through a confirmed plan and discharge. The City has a genuine desire to effect a plan to adjust its debts to protect its citizens from the financial disaster that would befall the City if the requested mandamus were granted. The City does not intend any improper purpose.

E. Fifth Requirement: Negotiations With Creditors Is Impracticable And Through Mandamus, Certain Creditors Would Receive A Preference.

The final requirement for Chapter 9 eligibility involves negotiations with creditors or a creditor's attempt to obtain an avoidable transfer. See 11 U.S.C. §109(c)(5). Negotiations with the creditors who have sued the City are impracticable. The size of the outstanding bond debt is overwhelming. Negotiations are impracticable with one group of creditors where negotiations with another key group have hit an impasse. See *In re Pierce County Housing Authority*, 414 B.R. 702,714 (Bankr. W.D. Wash. 2009). They may be equally impracticable where another part of the financial equation – a viable long-term financial plan based on revenues or expenses – cannot be determined. For example, where labor costs constitute the largest portion of the municipality's budget and no agreement could be reached through negotiations, it would be futile to negotiate with other creditors. See *In re City of Vallejo*, 408 B.R. 280, 298 (9th Cir. B.A.P. 2009). In the case of the City, negotiations with the principal

creditors who have sued the City and who seek mandamus which would have taxes paid to them and not to purchase essential services for the citizens of the City of Harrisburg would be impracticable to resolve the financial problems.

Alternatively, the City reasonably believes that the principal creditors who have brought legal actions are attempting to obtain a preference through the demand for a mandamus. The creditors who are prosecuting those legal actions against the City are likely to go on with their cases even if the City negotiates successfully with other creditors. The creditors have refused to defer their litigation while a plan under Act 47 was being negotiated. If they succeed in their litigation, the principal creditors will get a preference. But, the City does not have to wait for the entry of a judgment in mandamus to satisfy this requirement. It is satisfied based on the remedies sought in the pending litigation without any judgment in existence.

In addition to the eligibility requirements in Section 109(c) of the Code, Section 921(c) requires that a petition must be filed in “good faith”. The Code does not define “good faith”, but courts have determined that the primary function of the good faith requirement is “to ensure the integrity of the reorganization process by limiting access its protection to those situations for which it was intended.” *In re Sullivan County Reg’l Refuse Disposal Dist.*, 165 B.R. 60, 80 (Bankr. D.N.H. 1994). The City is filing its Petition in good faith. Its financial problems fall within the situations contemplated by Chapter 9 of the Code; it has filed the Petition for reasons consistent with the purposes of Chapter 9; it has considered alternatives to Chapter 9 but found them unsatisfactory and not in the best interests of the citizens of the City; and the nature and scope of the City’s financial problems can be handled by a Chapter 9 proceeding.

CONCLUSION

The City meets each of the five requirements to be a debtor in a case under Chapter 9 of the Code and has filed its Petition in good faith.

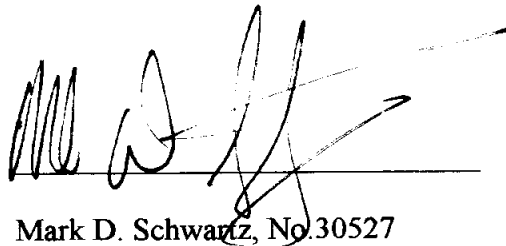
A handwritten signature in black ink, appearing to read 'Mark D. Schwartz', is written over a horizontal line. The signature is stylized and cursive.

Mark D. Schwartz, No.30527
David A. Gradwohl, No.18340

The Law Practice of Mark D. Schwartz, Esq.
P.O. Box 330
Bryn Mawr, Pa 19010-0330
Telephone & Fax 610-525-5534

Email:MarkSchwartz6814@gmail.com

COUNSEL FOR THE DEBTOR

EXHIBIT A

CITY OF HARRISBURG
October 11 , 2011

A RESOLUTION OF THE CITY COUNCIL OF CITY OF
HARRISBURG, PA AUTHORIZING FILING OF A PETITION UNDER
CHAPTER 9 OF THE UNITED STATES BANKRUPTCY CODE

BE IT RESOLVED, by the City Council of the City of Harrisburg as follows:

WHEREAS , the City of Harrisburg has previously submitted an application to the Commonwealth of Pennsylvania to be designated as “distressed” for purposes of Pennsylvania’s “Financially Distressed Municipalities Act”, Act of 1987, P.L. 246, No 47, commonly known as and referred to hereinafter as “ Act 47”; and

WHEREAS , the Pennsylvania Department of Community and Economic Development issued a determination that Harrisburg was financially distressed for purposes of Act 47 on December 15, 2010; and

WHEREAS, the “Governing Body” of the City of Harrisburg for purposes of Act 47 is this City Council; and

WHEREAS, this City Council has rejected an Act 47 Plan provided by the Act 47 Coordinator, a plan which neither meets the requirements of the Act, nor poses a practical financial solution to Harrisburg’s situation; and

WHEREAS, the City has previously defaulted on obligations with respect to outstanding debt, has experienced continued erosion of its finances, and has been faced with multiple lawsuits and pending takeover legislation initiated by parties including but not limited to Assured Guaranty Municipal Corporation seeking payment and preference in their positions over bondholders and other creditors.

WHEREAS Act 47 provides for the “Governing Body” to file a municipal debt adjustment action pursuant to the United States Bankruptcy Code (11 U.S.C. 101 et seq.) should one of five conditions of the Act be met;

WHEREAS, the Council has determined that at least four of the five conditions of Act 47 have been met; namely that:

-There is imminent jeopardy of action by a creditor, claimant or supplier of goods or services which is likely to substantially interrupt or restrict the continued ability of Harrisburg to provide health or safety services to its citizens.

-One or more creditors of the municipality have rejected the proposed or adopted plan, and efforts to negotiate a resolution of their claims have been unsuccessful for a ten-day period.

-A condition substantially affecting the municipality’s financial distress is potentially solvable only by utilizing a remedy exclusively available to the municipality through the Federal Municipal Debt Readjustment Act (48 Stat.798)

-A majority of the current or immediately preceding governing body of a municipality determined to be financially distressed has failed to adopt a plan or to carry out the recommendations of the Act 47 coordinator; and

WHEREAS, given that the City of Harrisburg has met Act 47's applicable provisions, and given that this Council as the designated "Governing Body" has determined that it is in the best interests of the citizens of Harrisburg, Pennsylvania, its citizens and other interested parties to invoke Act 47's provisions and file a petition and proceedings under Chapter 9 of the United States Bankruptcy Code on behalf of the City of Harrisburg which provides the City of Harrisburg with the necessary protection from its creditors while it develops and negotiates a plan for adjusting its debts.

NOW THEREFORE, BE IT RESOLVED by Harrisburg City Council that Mark D. Schwartz, Esquire is fully authorized and directed to prepare and file a petition for protection under Chapter 9 of the United States Bankruptcy Code on behalf of and in the name of the City of Harrisburg. Councilperson Susan Wilson is hereby authorized and directed, on behalf of and in the name of the City of Harrisburg, to execute and verify such petition, schedules, lists and other papers to cause the same to be filed with the United States Bankruptcy Court for the Middle District of Pennsylvania and to take any and all actions which they shall deem necessary and proper in connection with said Chapter 9 case with a view to the successful completion of such case.

ADOPTED by the City Council of the City of Harrisburg at a meeting
held on October 11, 2011.

RS _____

ATTEST: HS _____

EXHIBIT B

VII. THA FACILITY-RELATED DEBT CHART

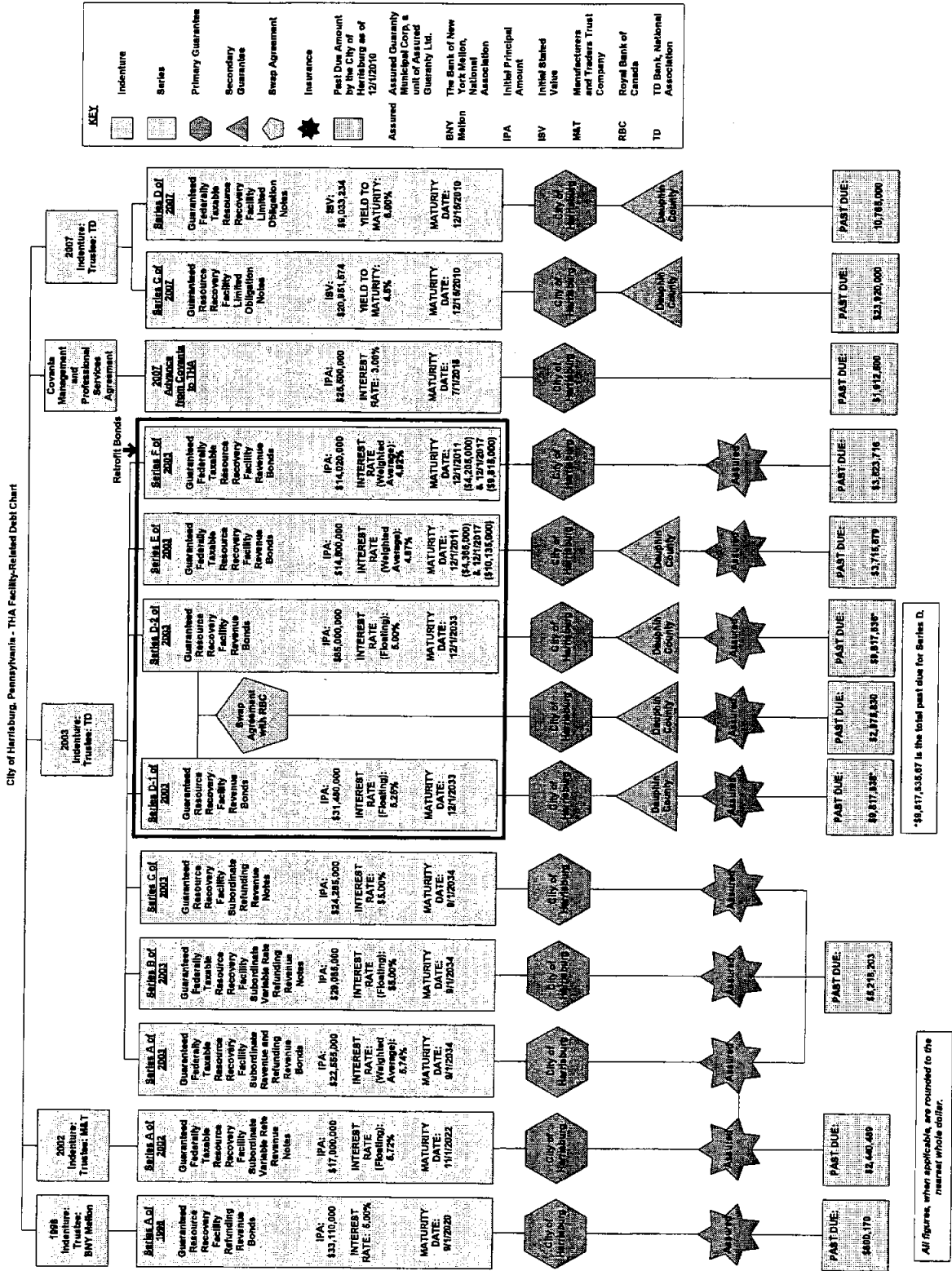

EXHIBIT C

II. City Financial Position

The City guarantees \$242 million of debt at THA/RRF – to be current by FYE 2011, the City will need to cover a combined \$83 million of past due payments and 2011 debt service

THA/RRF Debt (as of 12/31/2010) (in Millions)	A 2011		B 2011		C		D = A+B+C		E	
	Principal Due	Interest Due	DSRF	Past Due Owed by City	AGM	Total	Debt Service and Past Due	Total Principal Outstanding at 1/1/2011	Total Principal at 1/1/2011	Total Principal at 1/1/2011
County Guaranteed/AGM Insured:										
Revenue Bonds, Series D of 2003	\$ -	\$ 6.40	\$ 8.00	\$ 4.79	\$ -	\$ 12.79	\$ 19.19	\$ 96.48	\$ 109.27	
Revenue Bonds, Series E of 2003	1.52	0.58	1.10	2.62	-	3.72	5.82	11.66	15.37	
Notes, Series C of 2007	-	-	-	23.92	-	23.92	23.92	-	23.92	
Notes, Series D of 2007	-	-	-	10.77	-	10.77	10.77	-	10.77	
County Guaranteed/AGM Insured	1.52	6.98	9.10	42.09	-	51.19	59.69	108.14	159.33	
AGM Insured										
Revenue Bonds, Series A of 1998	-	0.56	0.60	-	-	0.60	1.16	11.17	11.77	
Notes, - e - - - - -	0.84	0.81	0.80	-	1.64	2.44	4.09	14.08	16.52	
Revenue Bonds, Series A, B, C of 2003	-	3.32	5.22	-	-	5.22	8.53	75.93	81.14	
Revenue Bonds, Series F of 2003	1.47	0.57	1.12	-	2.40	3.52	5.56	11.28	14.80	
Total AGM Insured	2.31	5.25	7.74	-	4.04	11.78	19.33	112.45	124.23	
Covanta Loan (City Backed)	1.89	0.15	-	-	-	1.91	3.95	21.04	22.95	
Total THA/RRF Debt Service	\$ 3.41	\$ 12.37	\$ 16.84	\$ 42.09	\$ 4.04	\$ 64.89	\$ 82.97	\$ 241.62	\$ 306.51	

Sources: a. Data from City Controller's Office; b. Indentured Trustee Data
 Notes: 1. The City is obligated to replenish the DSRF to remain current on the existing notes and bonds
 2. Consists of principal due in 2011 and all principal due from 1/1/2012 onward for each issue



EXHIBIT D

II. City Financial Position

The Act 47 Coordinator's projection of the City's 2011 Budget reflects a deficit of \$3.0 million, even before THA guaranteed debt obligations

City Budget Summary¹				
	2010		2011	Variance
	Actual	Projected	Projected	Fav/(Unfav)
Revenues:				
General Fund Revenue	\$ 37.40	\$ 44.51	\$ 44.51	7.10
Water Fund Revenue	16.08	18.19	18.19	2.11
Sewer Fund Revenue	13.73	14.62	14.62	0.89
Sanitation Fund Revenue	4.12	4.47	4.47	0.35
State Liquid Fuels Fund Revenue	0.89	0.89	0.89	(0.00)
Other Revenue / Asset Sales	0.51	1.01	1.01	0.50
Total City Revenue	72.74	83.70	83.70	10.96
Operating Expenses:				
General Fund	40.63	44.79	44.79	(4.15)
Water Fund	3.36	4.02	4.02	(0.66)
Sewer Fund	4.87	7.40	7.40	(2.53)
Sanitation Fund	1.48	1.76	1.76	(0.28)
State Liquid Fuels Fund	0.75	0.89	0.89	(0.15)
Total City Operating Expenses	51.08	58.85	58.85	(7.78)
Operating Surplus	\$ 21.66	\$ 24.84	\$ 24.84	3.18
Non-Operating Expenses:				
Cap Ex	0.28	0.40	0.40	(0.12)
Debt Service (General Fund)	11.50	12.22	12.22	(0.72)
Debt Service (Water Fund)	13.18	10.88	10.88	2.29
Debt Service (Sewer Fund)	2.05	2.16	2.16	(0.11)
Non-Operating Expenses	27.01	25.66	25.66	1.35
Act 47 Adjustment²		(2.18)	(2.18)	(2.18)
Surplus / Deficit²	\$ (5.35)	\$ (3.00)	\$ (3.00)	2.35

Sources: a. Data from City Controller's Office; b. Water Fund Budget (THA)

Notes: 1. See Appendix - City Interfund Detail for further information

2. The Act 47 Coordinator has run a detailed forecast of the 2011 City budget and projects a deficit of approximately \$3.0 million

**DECLARATION UNDER PENALTY OF PERJURY ON BEHALF OF A
MUNICIPALITY**

I, Susan Wilson of the City of Harrisburg, Pennsylvania, am a duly authorized officer or agent of the municipality named as a debtor in this case. I declare under penalty of perjury that I have read the foregoing Statement of Qualifications under Section 109(c), and the facts set forth in the Statement are true and correct to the best of my information and belief.

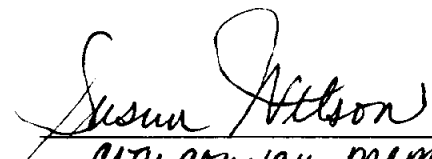
CITY COUNCIL MEMBER
BUDGET AND FINANCE CHAIR

Dated: October 11, 2011

PO Box 330
Bryn Mawr, PA. 19010
Telephone: 610 525-5534
Fax 610 525-5534
Markschwartz5814@gmail.com

**Law Office of Mark
D. Schwartz**

Fax

To: Clerk of Bankruptcy Court	From: Mark D. Schwartz, Esquire
Fax: 717 901-2822	Pages: 32
Phone:	Date: October 11, 2011
Re: Harrisburg Chapter 9 filing	cc:
<input type="checkbox"/> Urgent <input type="checkbox"/> For Review <input type="checkbox"/> Please Comment <input type="checkbox"/> Please Reply <input type="checkbox"/> Please Recycle	

Kindly docket the attached filing as of this date. I will be coming by in the morning to give you the original and pay filing fee.

MDS

***** UF-8000 v2 ***** - - - - - 17172336830-*****

- HILTON SALES SALES -

STN	COMM.	STATION NAME/EMAIL ADDRESS/TELEPHONE NO.	PAGES	DURATION
001	OK	99012822	031/031	00:03:11

FILE NO.=248

MODE = MEMORY TRANSMISSION START=OCT-11 22:26 END=OCT-11 22:29

***** -COMM. JOURNAL- ***** DATE OCT-11-2011 ***** TIME 22:29 *****

PO Box 330
Bryn Mawr, PA. 19010
Telephone: 610 525-5534
Fax 610 525-5534
Markschwartz6814@gmail.com

**Law Office of Mark
D. Schwartz**

Fax

To: Clerk of Bankruptcy Court	From: Mark D. Schwartz, Esquire
Fax: 717 901-2822	Pages: 32
Phone:	Date: October 11, 2011
Re: Harrisburg Chapter 9 filing	cc:

Urgent **For Review** **Please Comment** **Please Reply** **Please Recycle**

Kindly docket the attached filing as of this date. I will be coming by in the morning to give you the original and pay filing fee.

MDS